

Problems for chapter 4.

Revision Momentum is changed by external forces.

Conservation of momentum: $m_1v_{1x} + m_2v_{2x} = m_1v'_{1x} + m_2v'_{2x}$ when no external forces
 $m_1v_{1y} + m_2v_{2y} = m_1v'_{1y} + m_2v'_{2y}$ act.

Centre of mass $\mathbf{r}_{cm} = \frac{\sum m\mathbf{r}}{\sum m}$ and $\mathbf{v}_{cm} = \frac{\sum m\mathbf{v}}{\sum m}$

$$F = \frac{m(v - v_0)}{t} = ma$$

Force can be found from the slope of the momentum p vs t curve.

The change in momentum (impulse) is found from the area under the p vs t curve.

$$\sum \mathbf{F} = m\mathbf{a}$$

For equilibrium $\sum \mathbf{F} = \mathbf{0}$ and the sum of moments are zero, $\sum s_i F_i = 0$, where s is the direct distance from any possible turning axis to the line of action of the force OR the forces acting on the body meet at a common point. A rigid body can be treated as a point mass (or free body) when all forces act through the center of mass.

1.* A helpless traveller of mass 60.0 kg is sliding along a frozen river towards a frozen waterfall with a speed of 0.80 m s^{-1} , the traveller is sitting on a 20.0 kg sledge that moves across the ice with no friction. In desperation the traveller takes off his heavy boots (of mass 1.10 kg) and throws them away in order to slow down or stop. At what speed and in what direction should the traveller throw his boots? Just in time the traveller comes to his senses and jumps off the sledge instead, after this jump he moves at 0.50 m s^{-1} from the waterfall (icefall really) at what speed does the sledge reach the waterfall?

2.* In question 1. there are three situations described:

- i the traveller boots and sledge move with a common speed of 0.80 m s^{-1} ,
- ii the traveller and sledge have stopped and the boots keep moving,
- iii the traveller and boots move back at 0.50 m s^{-1} .

Find the speed of the centre of mass of the system (traveller boots and sledge) for each case.

3. A helpless traveller of mass 60.0 kg is sliding along a frozen river towards a frozen waterfall with a speed of 0.80 m s^{-1} , the traveller is sitting on a 20.0 kg sledge that moves across the ice with no friction. In desperation the traveller thinks to fire some rifle bullets in the direction that the sledge is running. These bullets each have a mass of $50 \times 10^{-3} \text{ kg}$ and a muzzle speed of 500 m s^{-1} . How many bullets must be fired before the traveller comes to rest or is just moving backwards? Instead of firing bullets, the traveller throws the 8.0 kg rifle at 12 m s^{-1} instead. Will this strategy work?

4. In question 3. there are two situations described:

- i the traveller, rifle and sledge move with a common speed of 0.80 m s^{-1} ,
- ii the traveller and sledge go in one direction while the rifle moves in the other.

Find the speed of the centre of mass of the system (traveller, rifle and sledge) for each case.

5.* “The bigger they are the harder they fall”. In a game of rugby (either code) a 105 kg forward takes the ball up with a speed of 6.5 m s^{-1} , a lighter back with a mass of 75 kg is expected to stop the forward dead in his tracks, at what speed must he make the tackle? If the contact in the tackle lasts for 0.13 s, what averages magnitude of force does each player experience in the tackle? If instead of running into the tackle the back stands and waits, but the tackle is still almost instantaneous, what is the speed of the players after the tackle?

6. In a game of basketball (any code) a forward catches the 0.38 kg ball with a speed of 12.5 m s^{-1} , as she catches it in her arms the ball comes to rest in 0.30 s. What average magnitude of force does the player experience in taking the catch standing still? If instead she runs into the ball, catches it in 0.30 s and takes it forward with a speed of 7.0 m s^{-1} , (in the opposite direction to that the ball was travelling) what is the average force that she experiences?

7.* A golf ball moving low and horizontally with a speed of 30 m s^{-1} hits a curb and bounces straight up into the air with a speed of 20 m s^{-1} . If the ball is in contact with the curb for 0.025 s and it has a mass of 0.080 kg, what horizontal force is required to stop the horizontal motion and what vertical force is required to give the ball the vertical motion? What is the strength of the average force during the collision?

8. A golf ball moving low and horizontally with a speed of 25 m s^{-1} hits a curb and bounces straight up into the air with a speed of 20 m s^{-1} . If the ball is in contact with the curb for 0.022 s and it has a mass of 0.080 kg, what horizontal force is required to stop the horizontal motion and what vertical force is required to give the ball the vertical motion? What is the strength of the average force during the collision?

9.* A car of mass 1050 kg coasts along a horizontal road with a constant resistance force slowing it down. If it is initially coasting at 20 m s^{-1} and after 10 s it has slowed to 11 m s^{-1} what is the strength of the force that is slowing it down? How long will the car take to come to rest, if the same force continues to act?

10. A car of mass 950 kg coasts along a horizontal road with a constant resistance force slowing it down. If it is initially coasting at 15 m s^{-1} and after 8.0 s it has slowed to rest, what is the strength of the force that is slowing it down?

11.* The momentum of two skate boarders is shown in the following p vs. t graph. Skateboarder A has a mass of 50 kg, while skateboarder B has a mass of 40 kg. The two skaters

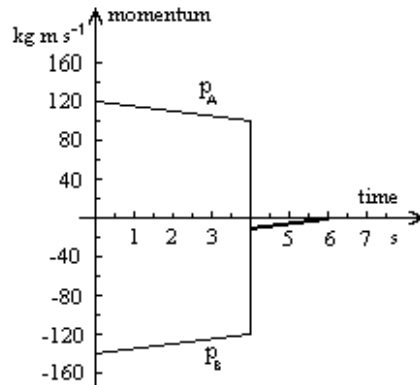

approach each other and cling together at 4 seconds, after this collision they continue with a common speed, but as they have different masses they can't have a common momentum. Use the graphical data to find the momentum of each skate boarder just before and after the collision. What is the magnitude of the frictional force on each skateboarder before they collide? Note: if you can't take accurate numbers from the graph do your best with estimates, this is why the masses have only been given to two significant figures.

12. The momentum of two skate boarders is shown in the following p vs. t graph. Skateboarder A has a mass of 50 kg, while skateboarder B has a mass of 40 kg. The two skaters

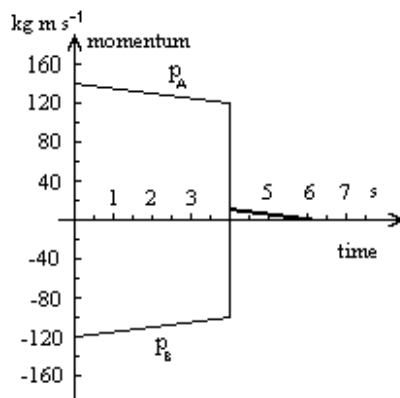

approach each other and cling together at $t = 4.0$ s, after this collision they continue with a common speed, but as they have different masses they can't have a common momentum. Use the graphical data to find the momentum of each skate boarder just before and after the collision. What is the magnitude of the frictional force on each skateboarder before they collide? Note: if you can't take accurate numbers from the graph do your best with estimates, this is why the masses have only been given to two significant figures.

13.* In a classic Nordic fairy tale a goat crosses a bridge. Let the weight of the goat be 400 N. Let the bridge be a light uniform plank that doesn't bend of length 3.0 m from support to support and let the bridge be horizontal. Vertical support forces F_1 and F_2 act

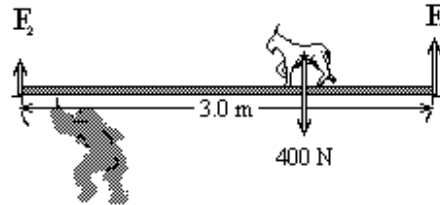

from the ends of the bridge, calculate the magnitudes of F_1 and F_2 as the goat is one third, one half and two thirds of the way across the bridge.

14. This time two goats walk across a bridge in opposite directions, as shown below. If the larger goat is 1.0 m from one end of the bridge, how far has the smaller goat travelled if the same support forces, that is $F_2 = F_1$ act at either end of the bridge?

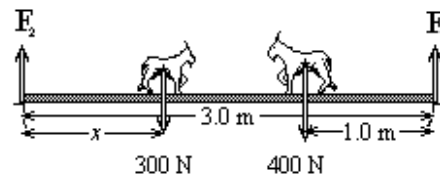

15.*

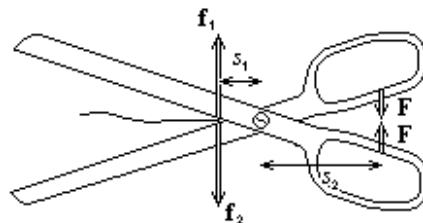

Write a formula for the strength of the forces that cut the material between the blades of the scissors (or shears) shown in the diagram. Each of these forces should be given in terms of s_1 , s_2 and $|\mathbf{F}|$.

16. A nut-cracker forms a different type of lever to the scissors, but the theory is identical.

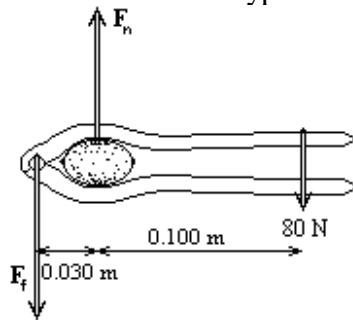

In the above diagram the forces on the upper arm of a nutcracker are shown, there will be equal and opposite forces acting on the lower arm but these are not shown. Use the theory of moments to find the magnitude of the force from the nut F_n and the force on the fulcrum F_f .